

## F300

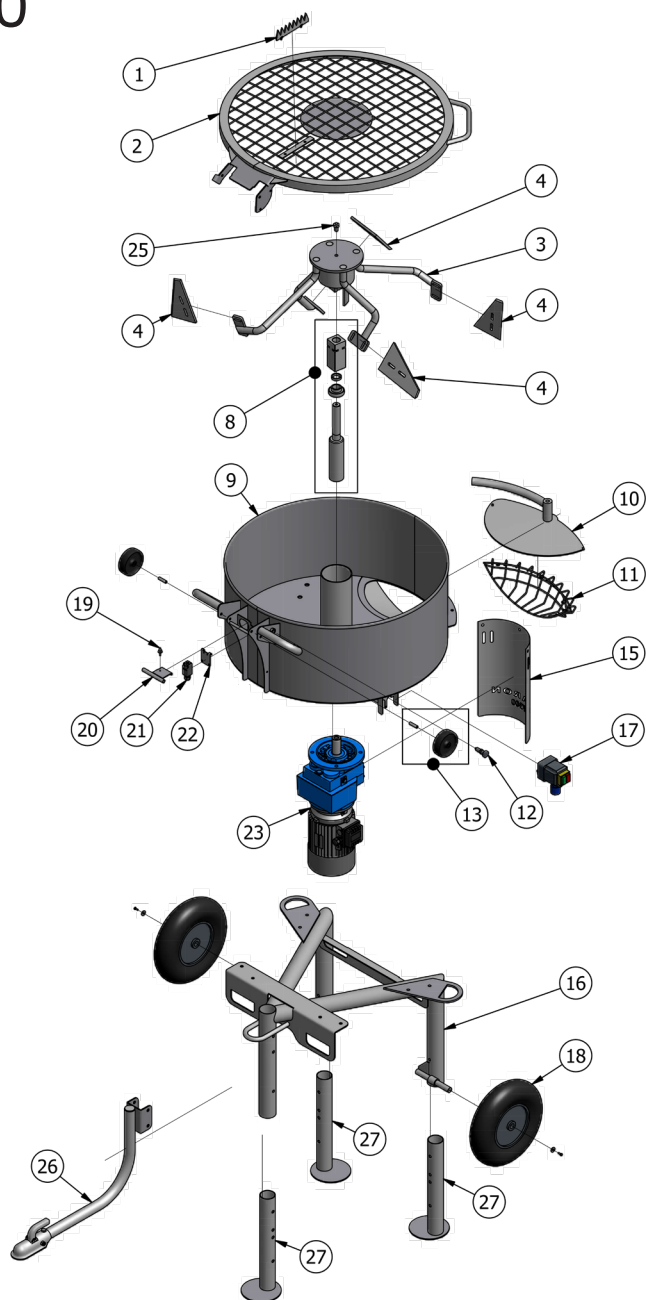

POS.	PART NO.	DESCRIPTION
1	50640	Sack knife, complete
2	50550	Cover
3	50427	Mixer head (without shovels)
4	50444	Metal shovels, complete (4 pcs)
8	50653	Drive shaft, complete, Fabrika motor
9	50512	Container
10	50376	Trapdoor, complete
11	50355	Outlet protection
12	50328	Positioning bolt
13	50343	Transportwheel, complete (1 pc)
15	50567	Engine cover
16	50525	Frame
17	50304	Main switch, 3x380V 6.3-10A, phase indicator
18	50341	Wheel, 25x75 (1 pc)
19	50327	Rubber damper
20	50603	Plate for cover switch
21	50326	Mechanical end switch
22	50600	Bracket for cover switch
23	50204	Motor + gear, 4kW 3x380V, Fabrika
25	50642	Top bolt with ball
26	50647	Transportarm
27	50538	Support leg (1 pc)
	50276	Starting contact 4kW K3 for main switch
	50279	Thermo relay for main switch

POS.	PART NO.	OTHER SPARE PARTS
	50461	Rubber shovels, complete set (4 pcs)
	50644	Traktorsplit, ø4x35
	50643	Traktorsplit, ø10x60
	50108	Extension cable, 3x380V CEE, 5m
	50106	Extension cable, 3x380V CEE, 10 m
	50535	Leg bolt
	50679	Dust cover (lid)